

kettal

4–29 Pavilion V by Vincent Van Duysen

30–79 Passage by Ronan Bouroullec

80–109 Insula by Patricia Urquiola

110–53 Kall by Kettal Studio



# Pavilion V, by Vincent Van Duysen

The V Pavilion project is based on the idea of creating a dialogue between different environments: the interior and exterior of architecture.

The gentle connection between people and the environment through constructive elements, a free floor and the importance of light.

The pavilion is designed to be subtly linked to the main building and the outdoor area at the same time.

V Pavilion is inspired by 1950s American modernism, which summarised a more industrial trend of thought based on new and innovative building technologies and on Functionalism, emphasising open-plan, multifunctional spaces that are flexible and easily adapted and modified for any lifestyle or environment.















The open areas between the columns can be assembled with various facings: glass, louvres to adjust the light, curtains, solid stoneware panels, cupboards, cooker, fireplace... to furnish a space that is customised to the client's specifications.







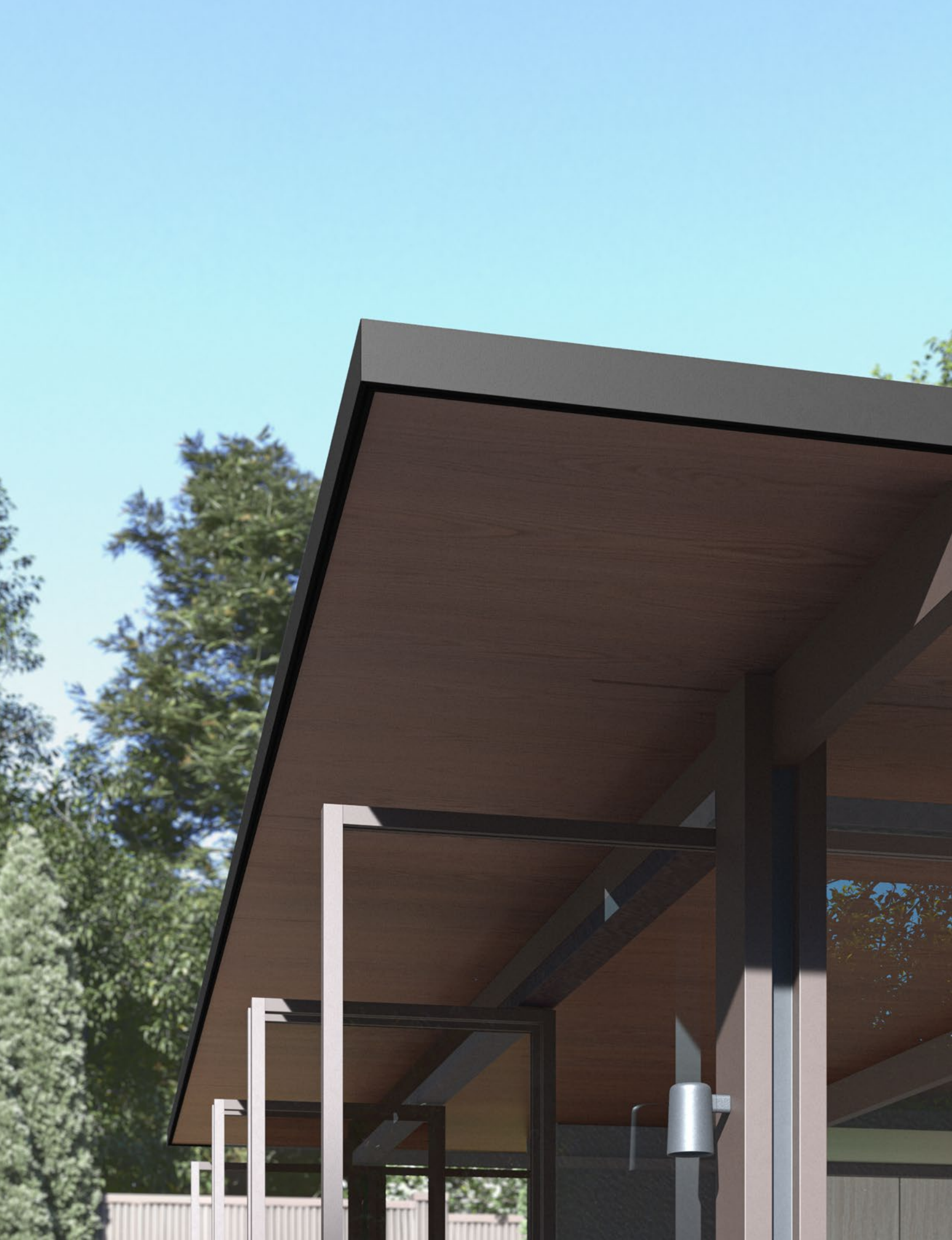

Pavilion V





















# Lighting

The V Pavilion prides itself on its extensive selection of lighting options, meticulously curated to enhance both the outer facade and inner sanctum. Along the periphery, discreet wall-mounted lights cast a gentle glow, accentuating the architectural lines and creating a welcoming aura. Delving deeper into its interior realms reveals a plethora of illuminative possibilities awaiting exploration.

Within, an eclectic mix of lighting fixtures stands ready to fulfill any lighting need. Versatile ceiling spotlights offer the freedom to focus beams precisely, whether for highlighting art pieces or illuminating workspaces. Adding a touch of sophistication are the suspended pendant lights, gracefully dangling to infuse spaces with a refined ambiance. Complementing these are the overhead luminaires, ensuring uniform brightness throughout the area.

Furthermore, the perimeter interior is adorned with an assortment of lighting styles, each contributing uniquely to the overarching ambiance. From warm, inviting hues to cool, contemporary tones, every corner boasts its distinctive luminous personality.

To add to the allure, all these lighting alternatives come with the added convenience of dimmability, effortlessly adjustable to suit any mood or occasion. Whether through a dedicated remote control or the intuitive Kode App, users wield the power to tailor their lighting experience to perfection, granting them unparalleled flexibility and customization options.

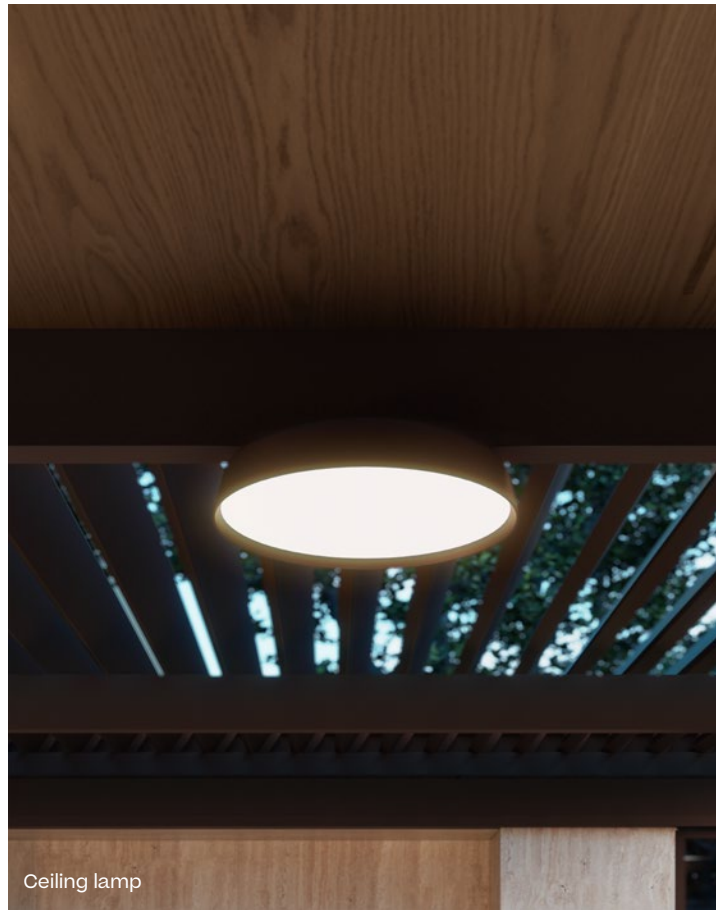





Lineal LED light



Perimetral LED



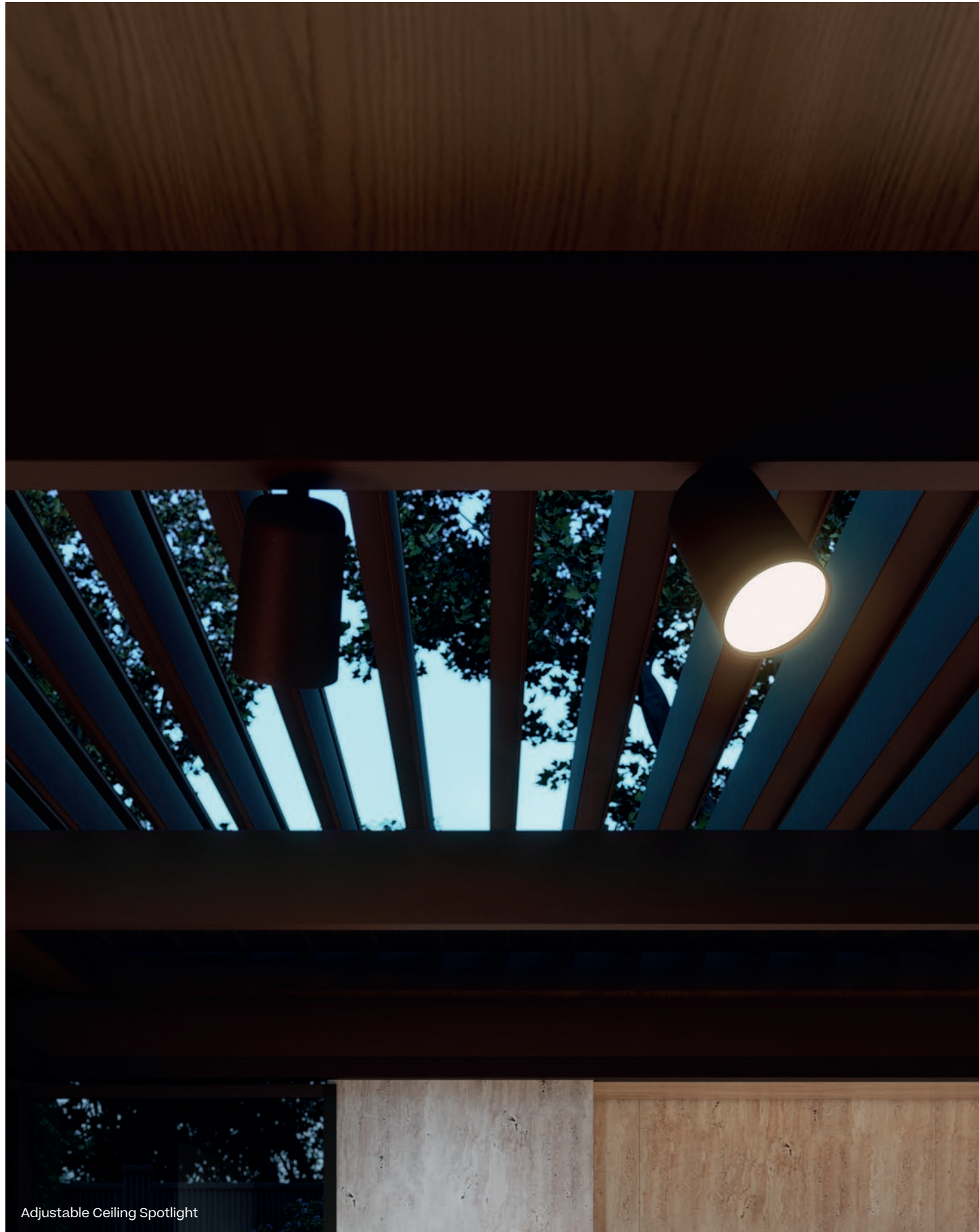

Adjustable Ceiling Spotlight



Switch



Plug

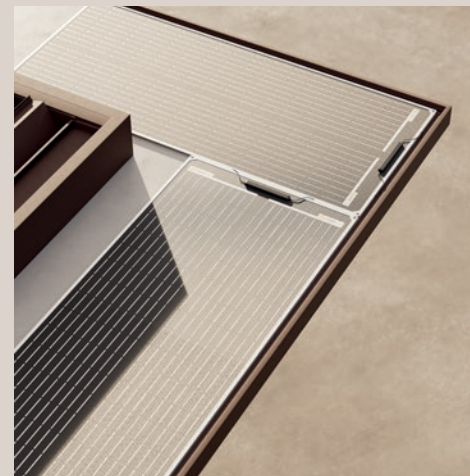

Solar panels & Battery

## Technology

The Pavilion V, by Vincent Van Duysen, offers an unprecedented level of control through its innovative interface options. Users can effortlessly manage the pavilion's features using conventional switches conveniently located throughout the structure. Alternatively, the cutting-edge Kode app, developed by Kettal, revolutionizes the user experience. Available for both iOS and Android devices, Kode empowers users to govern the pavilion's lighting independently, adjust the bioclimatic ceiling, and even regulate the fireplace—all with a simple tap on their smartphone or tablet. Furthermore, the flexibility extends to the pavilion's infrastructure, as waterproof outlets can be seamlessly integrated into the columns, enhancing convenience and functionality. With such intuitive control mechanisms, the Pavilion V epitomizes sophistication and technological advancement, elevating the standards of contemporary living.





# Passage, by Ronan Bouroullec



Passage as a concept is highly ambiguous and versatile and can be used to describe numerous actions and situations. Passage relates to movement, it describes passing or movement from one place to another, in relation to travel, literature or music.

The Passage chair has any number of uses; it can seamlessly pass from one situation to another, from one place to another, from one use to another... It can be placed indoors or outdoors, displayed in a public place or kept in the comfort of home, in an urban environment or in the country.

Passage is made of aluminium, because this light, resistant material best represents the changing nature of the chair. As well as being recycled and recyclable, it is highly durable, whatever its use, which greatly reduces the carbon footprint left by its manufacture.

Two important parts create the PASSAGE aluminium chair's unpretentious structure: firstly, a very simple tubular structure, which then supports the backrest and seat, manufactured as a single piece of extruded aluminium. The lightness and flexibility of the seat finishes give the object its unique capacity for adaptation.











Passage

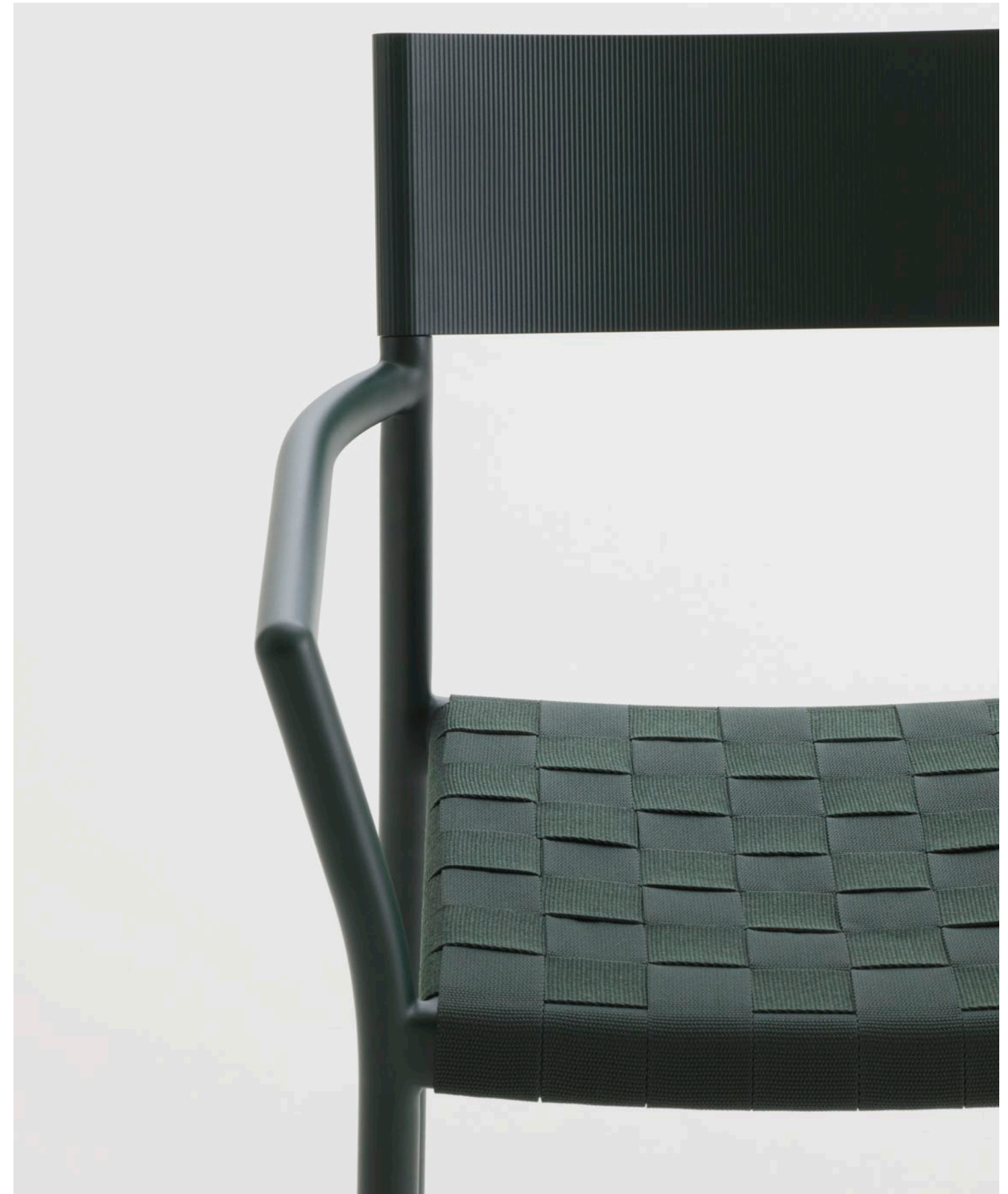
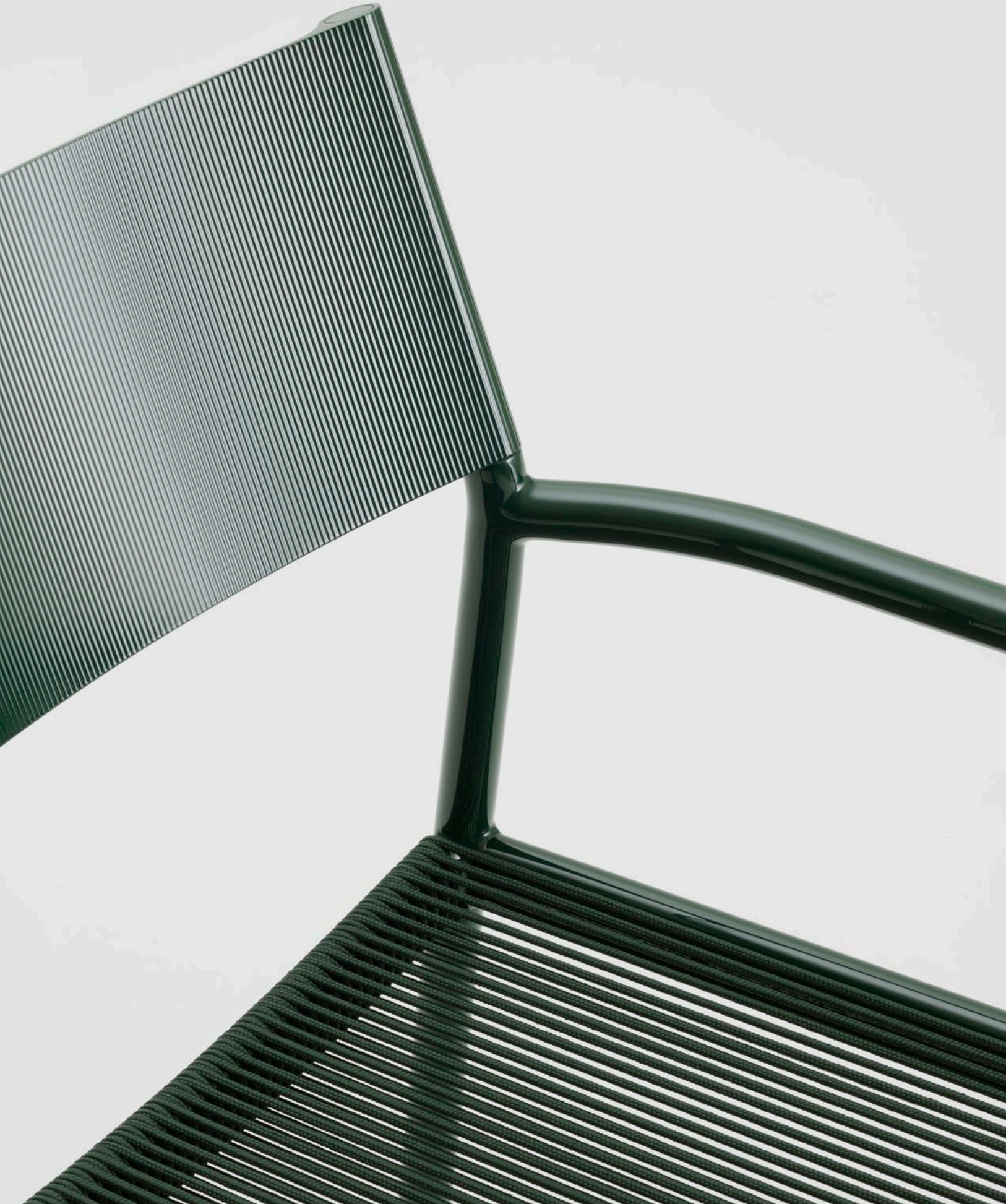







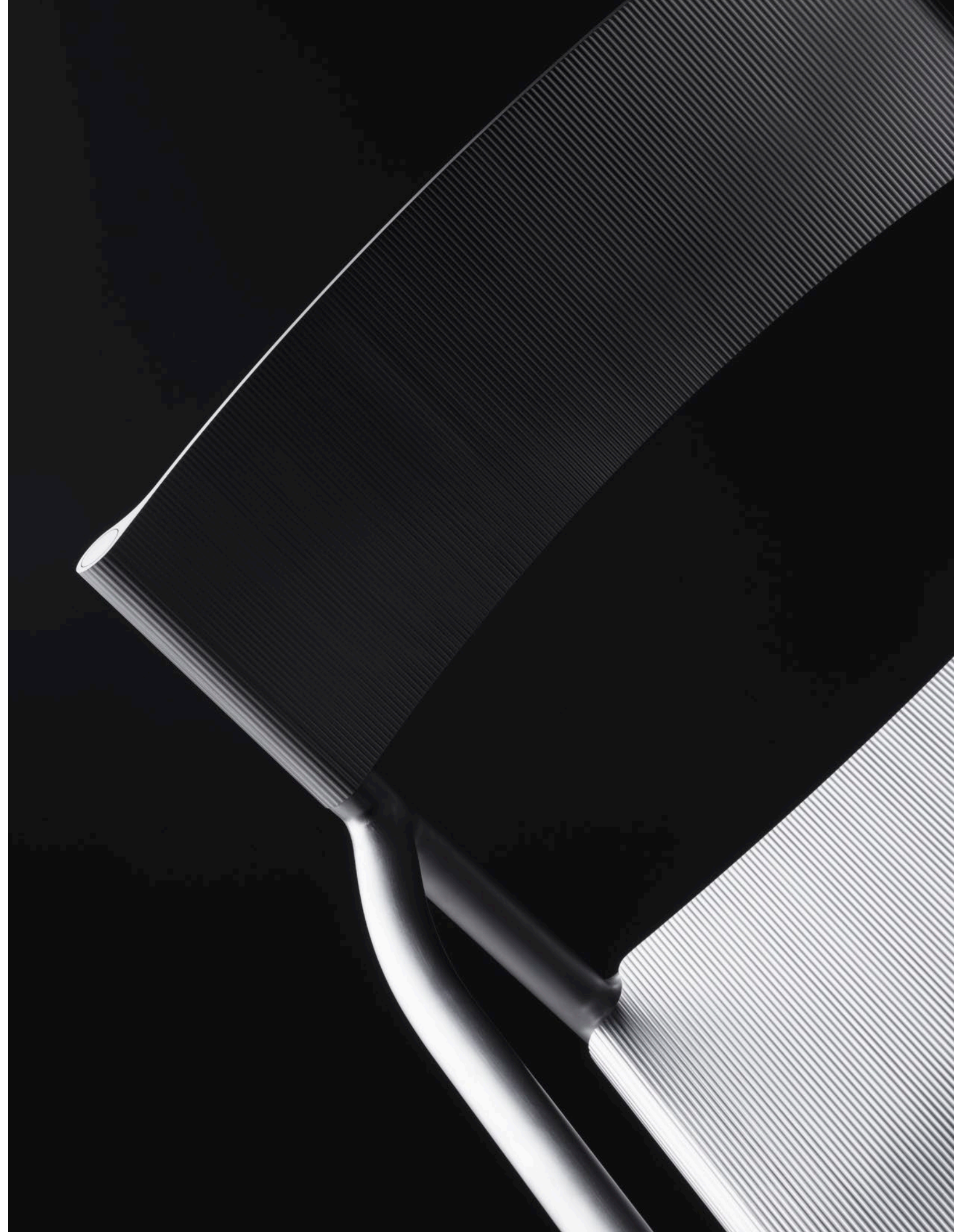
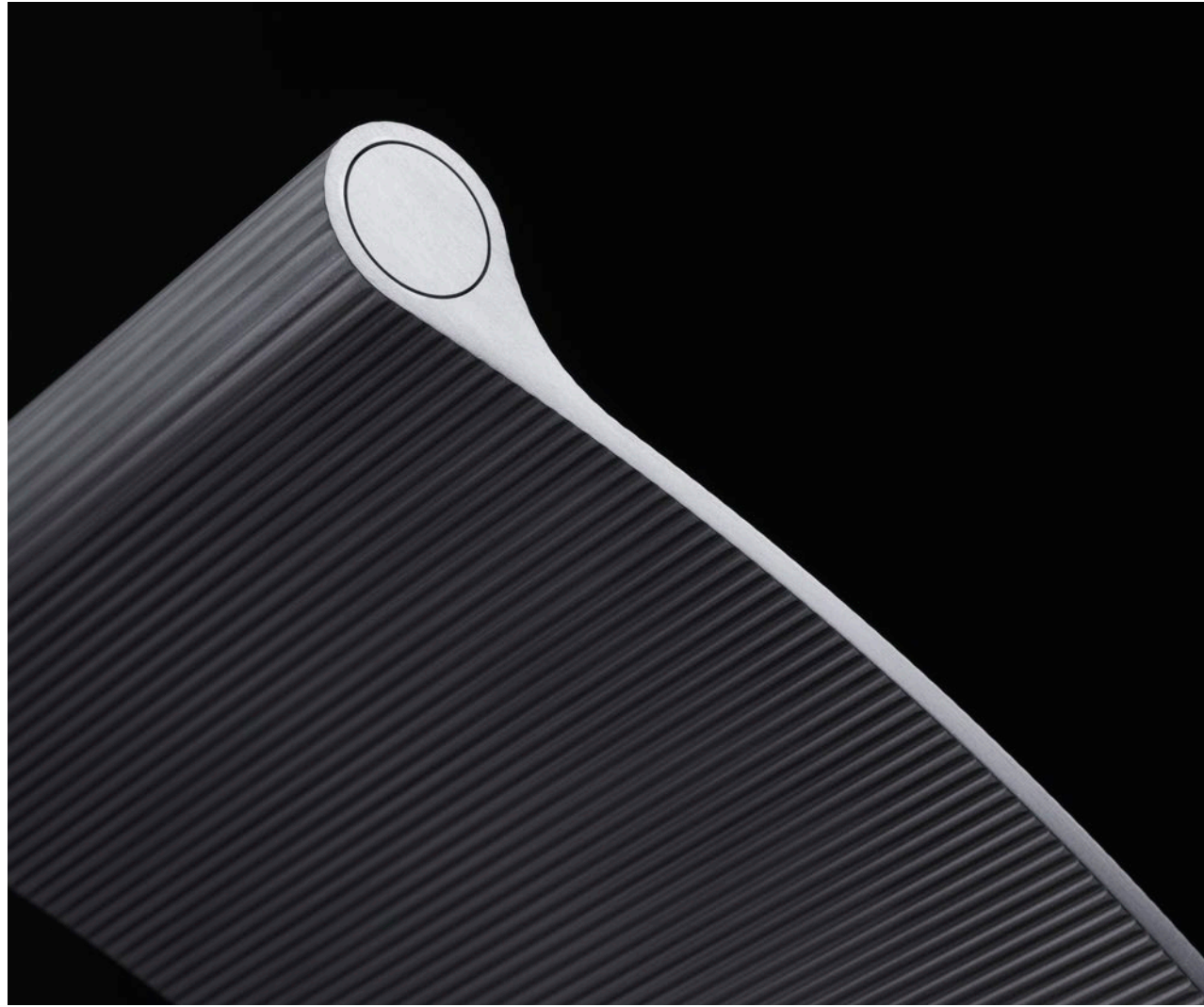







































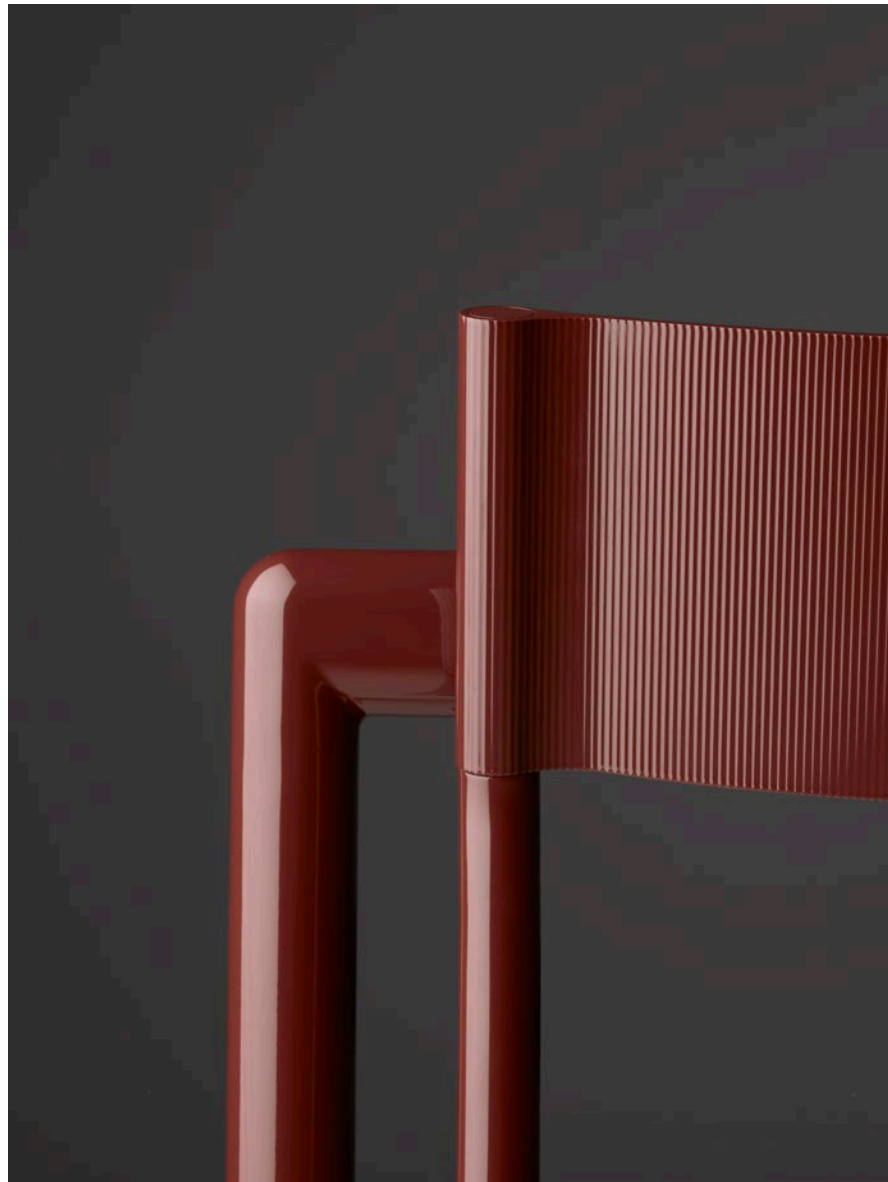

























Stackable dining armchair. Cabo rope

KSB500100

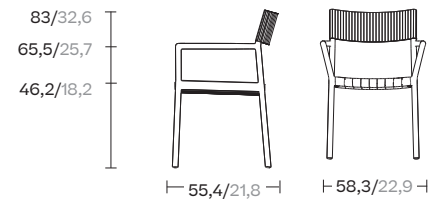

Stackable Dining chair. Cabo rope

KSB500400

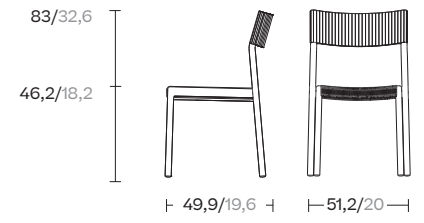

Stackable dining armchair. Roll strap stripes

KSB500200

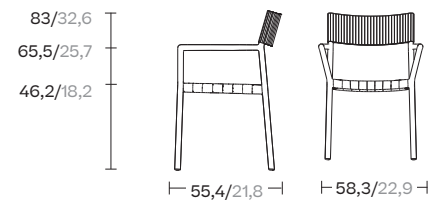

Stackable Dining chair. Roll strap

KSB500500

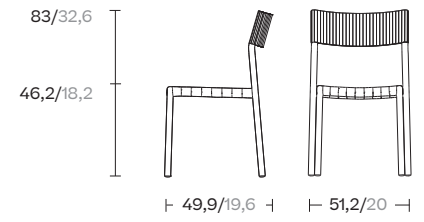

Stackable Dining chair. Umbra fabric

KSB500300

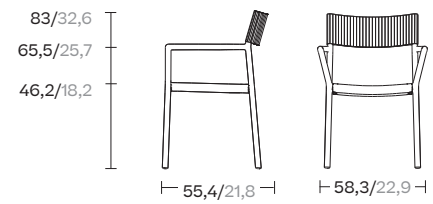

Stackable Dining chair. Umbra fabric

KSB500600

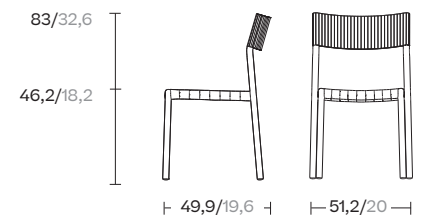





Dining armchair. Cabo rope

KSB500900

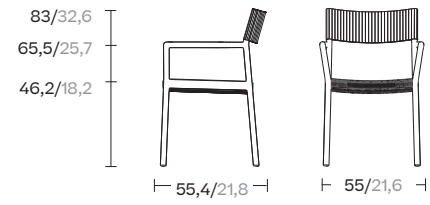

Dining armchair. Tapissé

KSB500800

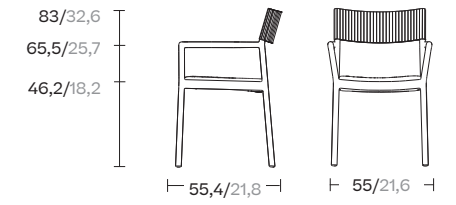

Dining armchair. Roll strap

KSB500900

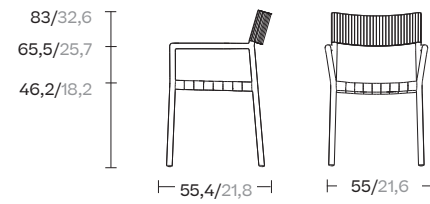

Dining armchair. Papiro Fiber

KSB501200



Dining armchair. Umbra fabric

KSB501100

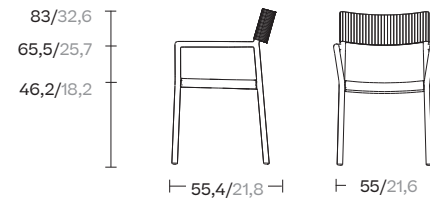

Dining armchair. Aluminium

KSB500700

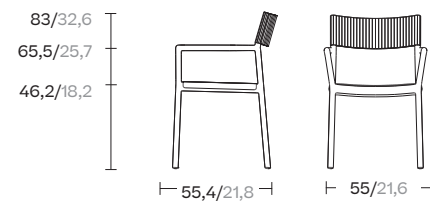





Stackable Club armchair. Cabo rope

KSB501400

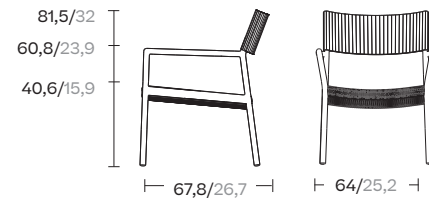

Stackable Club armchair. Rattan

KSB501200

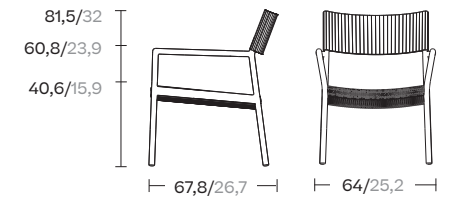

Stackable Club armchair. Roll strap

KSB501300

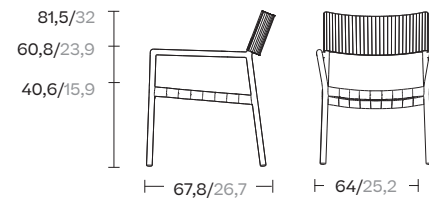

Stackable Club armchair. Umbra

KSB501500

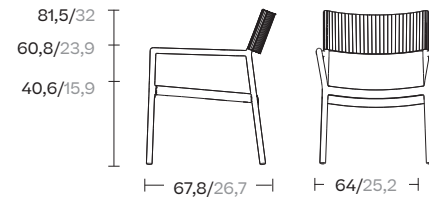

Stackable Club armchair. Tapissé

KSB501600

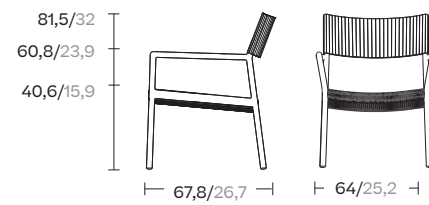





Dining armchair. Plywood

KSB501800

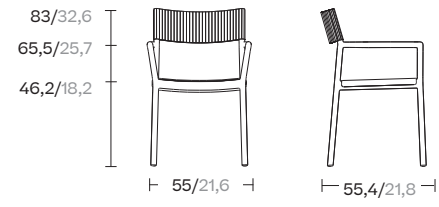

Club armchair. Plywood

KSB501900

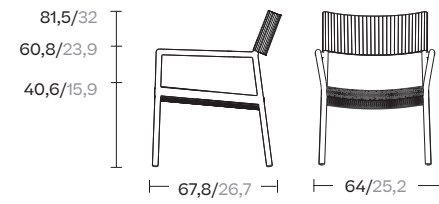

Dining table 100x100

KSB502000

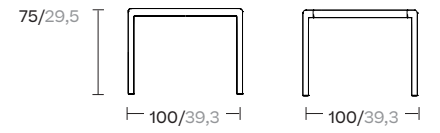

Dining table 220x100

KSB502100

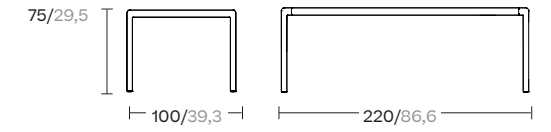

Dining table 280x100

KSB502200

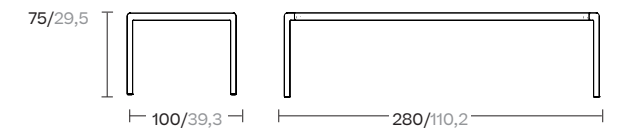

Centre table 100x100

KSB502300

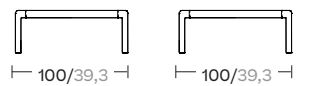



# Insula, by Patricia Urquiola

The Modular Insula sofa is Patricia Urquiola's updated interpretation of traditional seating used in traditional Arab Majlis, where community members gathered to discuss events and local issues, entertain guests, build friendships, and have fun.

Formally, it is a rational modular sofa with very softened shapes and low height, with a Insula in the backrest that concentrates all the protagonism of the design and provides a decidedly horizontal emphasis. It combines carefully balanced proportions as an architectural element that can be subtly integrated.

Functionally, like the original concept of Arab Majlis, the main function of the Insula sofa is socializing. The multitude of configurations allows it to adapt to all kinds of social situations, both indoors and outdoors: from the reception of an office where one can find a place to work relaxed, to resting in a home or outdoors for sunbathing and having fun. Its modular design consists of an orthogonal aluminum base with very softened shapes where the seat cushion, very plush and comfortable, is located. The two sizes of its seats allow for various types of backrests: individual, double, angular, etc.























































One seat module

KSB600700

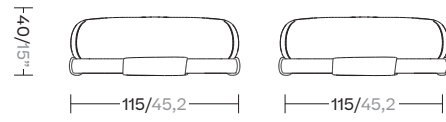

Two seat module

KSB601000

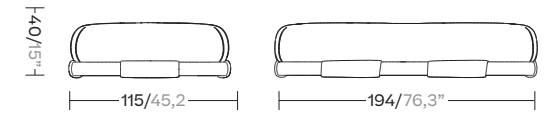

One seat module with cushion

KSB600800

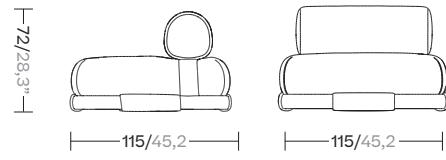

Two seat module with cushion

KSB601100

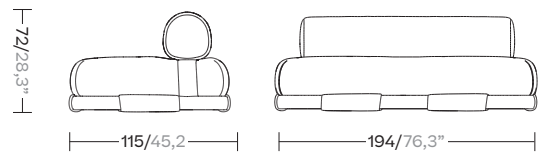

Corner module

KSB600900

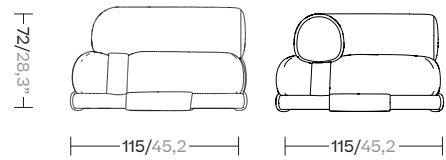

Daybed

KSB601100

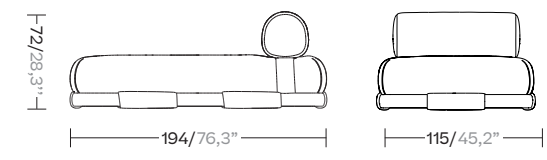





Square table

KSB601200

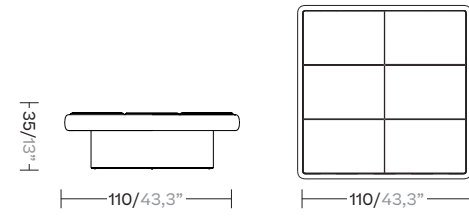

Rectangular table

KSB601300

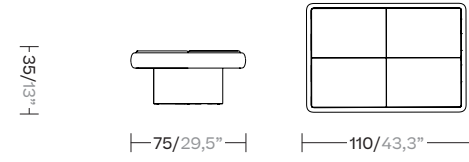

Side table  
(charger included)

KSB601400





# Kall

Introducing the Kall Collection - a modern solution for private and comfortable conversations. We believe that a phone booth should simply be the door of a meeting room, which is why we have made the glass door the protagonist, and the space of the "Phone booth" corresponds to the projection of this door, making it appear embedded against the wall when viewed frontally. Our design ensures minimalism and functionality without any unnecessary frills.

Privacy is a key aspect, and we understand that users need a discreet environment for confidential meetings. Our small side walls provide structural support while also maintaining privacy for documents, device screens, and even facial expressions during a conversation.

The addition of a translucent curtain further enhances the sense of protection against prying eyes wider, allowing for a swivel armchair, similar to a lounge room, with a relaxed work posture. We also offer an "L" version for two people and a "XL" for 4. We understand that a phone booth should not be a cold space, so we have created a warm and inviting

environment. Our design provides a pleasant atmosphere, making it closer to a meeting room or a home room rather than a typical elevator cabin. Technology is an essential component, and we have ensured that the technology is intuitive and userfriendly.

Everything is controlled electronically, with scene creation systems, table height regulation, ventilation control, and connectivity all intentionally hidden. Our interaction controls simulate the controls of old HIFI equipment, emphasizing that this booth is a simple and pleasant space where users can provide the main technology using their own devices. For tech-savvy users, we also offer a touchscreen control system.

The Kall Phone booth family consists of various sizes. The "S" is the basic and standard size. The "M" is 30cm.



















textt000t0t???





Kall S

KSB300100

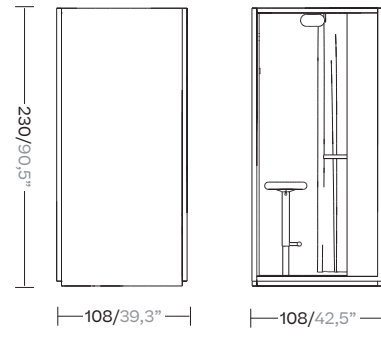

Kall L

KSB300300

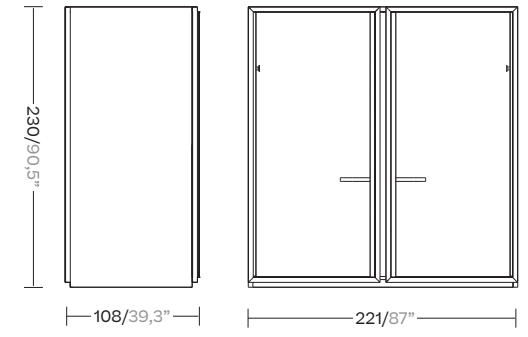

Kall M

KSB300200

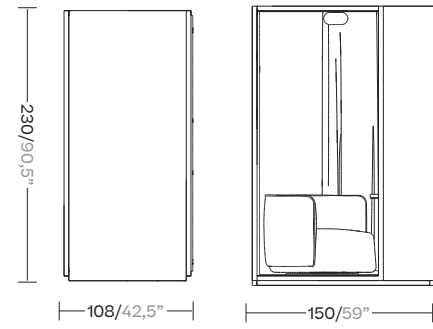

Kall XL

KSB300400

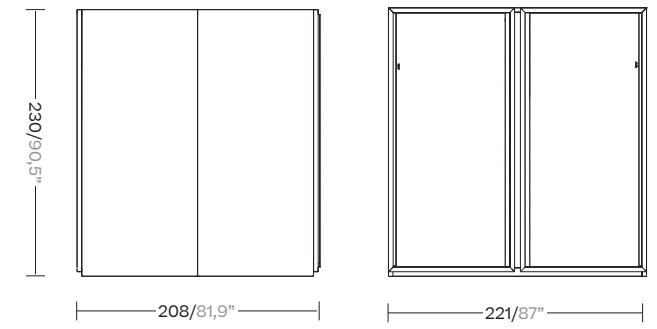

Analog controller

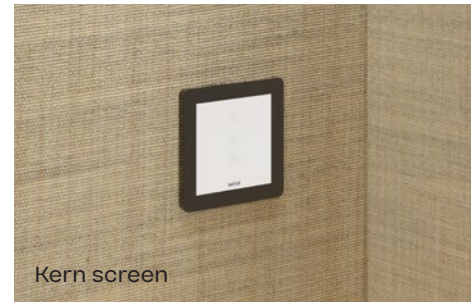

Kern screen



# Finishes

Finishes

Contemporary & elegant finishes  
for endless combinations.

The wide selections of materials include fabrics, metals, woods, stones and ceramics. All of these worlds form the basis of the library. We invite the professional to explore and combine colors, textures and materials to create exclusive codes for each project.



# Passage Materials

## Blanc d'ivoire version



Blanc Ivoire Glossy Paint



Blanc Ivoire Textured Paint

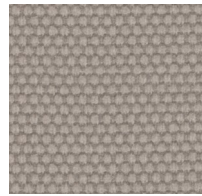

Cotton Strap

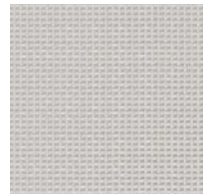

Blanc Ivoire Umbra fabric

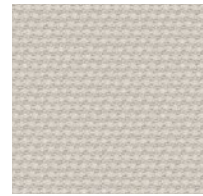

Snowcap Terrain Elements fabric



Blanc Ivoire Cabo Rope

## Noir d'ivoire Version



Noir d'Ivoire Glossy Paint

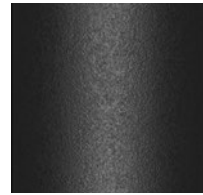

Noir d'Ivoire Textured Paint

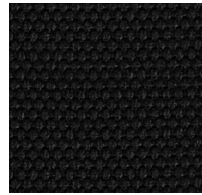

Noir d'Ivoire Strap

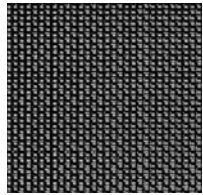

Noir d'Ivoire Umbra fabric

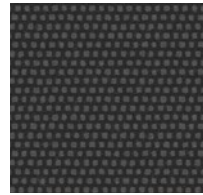

Charcoal Terrain Elements fabric



Noir d'Ivoire Cabo Rope

## Terre Sienne Version



Terre Sienne Glossy Paint



Terre Sienne Textured Paint

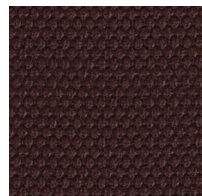

Plume Thistle Strap

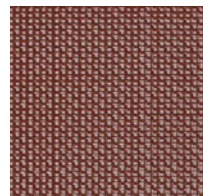

Terre d'Ombre Brulée Umbra fabric



Glove Terrain Elements fabric



Terre Sienne Cabo Rope

## Vert Version

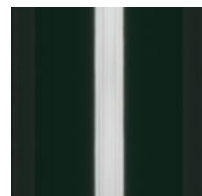

Vert Glossy paint



Vert Textured Paint

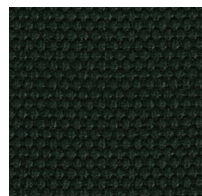

Vert Strap

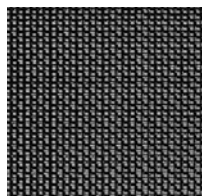

Noir d'Ivoire Umbra fabric

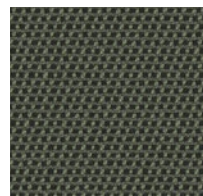

Peppercorn Terrain Elements fabric



Vert Cabo Rope

## Anodisé Version



Anodisé Paint



Anodisé Paint

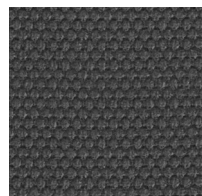

Silver Jade Strap

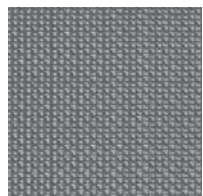

Gris Claire Umbra fabric

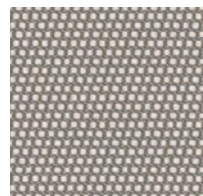

Porous Grey Terrain Elements



Gris Claire Cabo Rope

## Plywood



Oak Veneer



Oak Veneer Black Lacquer





# Insula Materials

## Terrain Paint

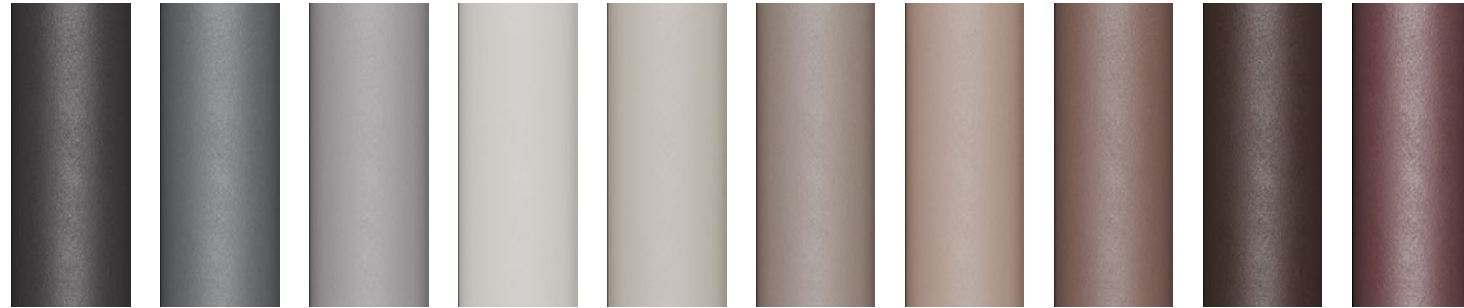

Slate Stone 01C    Misty Smoke 02C    Ash 03C    Bone 04C    Tuff 05C    Wet Stone 06C    Sand Dune 07C    Dry Clay 08C    Arabica 09C    Sepia 19C



Rose Canyon 16C    Blossom 20C    Ruby Dust 18C    Sunset Glow 17C    Terrarosa 15C    Terracota 14C    Amber 13C    Ginger Root 12C    Desert Storm 11C    African Savannah 10C

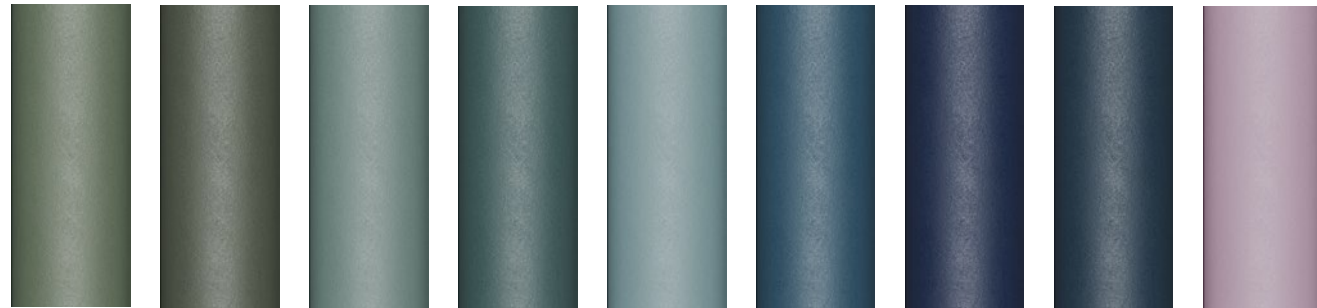

Spring Meadow 28C    Kombu 29C    Forest Stream 27C    Sea Moss 26C    Glacier Ice 25C    Polar Sky 24C    Nightfall 23C    Indigo 22C    Wild Lupin 21C



Galena 33C    Bronze 30C    Corten 31C    Manganese 32C

## Rockress (Only for Insula collection)



Silver Falls D1L    Black Velvet D2L    Summer Snow D3L    Cherry Caramel D4L    Red Robin D5L    Blue Thyme D6L

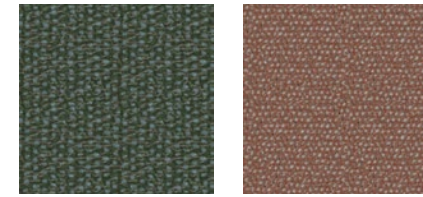

Silver Falls D7L    Arabis D8L

## Agate (Only for the table tops of the Insula collection)

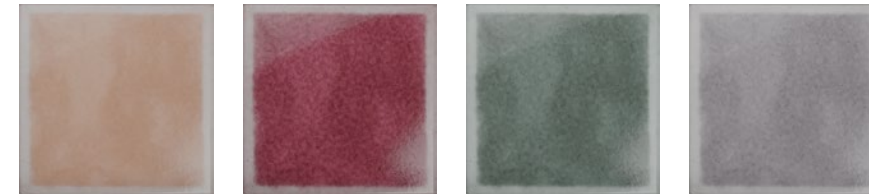

Camelian Agate    Indian Agate    Moss Agate    Botswana Agate



# Kall Materials

## Compact Wood/paint



Light Oak  
CW1

Desert Storm  
11C

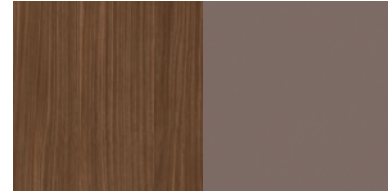

Dark Oak  
CW2

Dry Clay  
08C

## Outer Panel color



Soft Beige  
LW1



Soft Cream  
LW2



Light Brown  
LW3

## Interior



Rice Cake  
F01



Kall Curtain



Kall floor

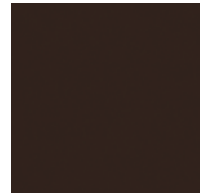

Arabica  
09C  
Adjustable stool chassis



Pecan Pie  
F04  
Adjustable stool fabric

## Waranty terms

For domestic use, all products, except for cushions, covers and fabrics (including textilines), are guaranteed for a period of five years against any manufacturing defect that affects their suitability for use. This applies to normal conditions of use and maintenance. This guarantee does not apply to faults or imperfections resulting from the passage of time or normal wear and tear. Circumstances not covered by this guarantee include, but are not limited to, the fading or change in shade of colours, changes in wood texture, scratches resulting from use, etc. For non-domestic use, by the hotel and catering industry and collectives for example, all products, except cushions, covers and fabrics, are guaranteed for a period of two years. This guarantee is subject to the same conditions as outlined above.

## Technical specifications

Committed to innovation and quality, Kettal's collections are manufactured to the strictest quality standards, from the selection of the materials, to the quality and safety testing of the furniture.

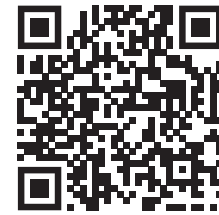

See all the finishes colors of each image here



# We would love to hear from you.

## Head office

Kettal Barcelona  
Aragón, 316  
08009 Barcelona, Spain  
T. (34) 93 487 90 90  
F. (34) 93 487 90 66

## Showrooms

Miami Showroom  
147 Miracle Mile  
Coral Gables,  
Florida 33134, USA  
t. (1) 786 552 90 22  
miami.store@kettal.es

New York  
The D&D Annex:  
222 East 59th Street  
Suite 222-333  
New York, NY 10022, USA  
t. (1) 917-992-9419  
newyork.showroom@kettal.com

Chicago  
The Mart.  
222 Merchandise Mart Plaza,  
Suite 377  
Chicago, IL 60654 USA.  
T. 312.244.0527  
chicago.showroom@kettal.es

London Showroom  
15-16 Dufferin St,  
London EC1Y 8PD, Reino Unido  
t. +44 7498 846 352

Paris Showroom  
80, Blvd Malesherbes  
75008 Paris, France  
t. (33) 1 43 59 51 40  
boutique.paris@kettal.es

Melbourne Showroom  
510 Church Street Melbourne  
Richmond VIC 3121, Australia  
t. (03) 9957 8799

Kettal Barcelona  
Aragón, 316  
08009 Barcelona, Spain  
T. (34) 93 488 10 80  
tienda.bcn@kettal.es

Marbella Showroom  
Crtra. de Cádiz, Km.179  
(entre el Marbella Club  
y el Guadalpin)  
29600 Marbella, Spain  
t. (34) 95 277 89 89  
tienda.marbella@kettal.es

## Press Kit



To download the Press Releases and  
high res images please register in the  
Press Area here